

Upstage Plaster Line	30'-0"	
Upstage Fire Curtain	29'-3"	43
Cyclorama	28'-9"	42
Rear Projection Screen (Black)	28'-3"	41
#3 Traveller Does not move	27'-9"	40
Spare	27'-3"	39
Scrim	26'-9"	38
#6 Border	26'-3"	37
#6 Leg	25'-9"	36
#5 Electric Does not move	24'-9"	35
#5 Border	23'-3"	34
#5 Leg	22'-3"	33
Moving Light Truss	21'-3"	32
Moving Light Truss	20'-9"	31
#4 Electric Does not move	19'-9"	30
Spare	18'-3"	29
#4 Legs	18'-3"	28
Spare	17'-9"	27
#4 Border	17'-3"	26
Spare	16'-9"	25
#3 Electric Does not move	15'-9"	24
#3 Legs	14'-9"	23
#3 Border	14'-3"	22
Spare	13'-9"	21
#1 Traveller Does not move	13'-3"	20
Spare	12'-3"	19
Spare	11'-9"	18
Spare	11'-3"	17
Spare	10'-9"	16
#2.5 Electric Does not move	10'-3"	15
#2 Electric Does not move	9'-3"	14
#2 Legs SR	8'-3"	13
#2 Legs SL	7'-9"	12
#2 Border	7'-3"	11
Spare	6'-9"	10
Spare	6'-3"	9
#1 Electric Does not move	5'-3"	8
#1 Leg	4'-3"	7
#1 Border	3'-9"	6
Full Black Reveal	3'-3"	5
Spare	2'-9"	4
Spare	2'-3"	3
Main Curtain	1'-9"	2
Downstage Fire Curtain	0'-3"	0
Downstage Plaster Line	0'-0"	

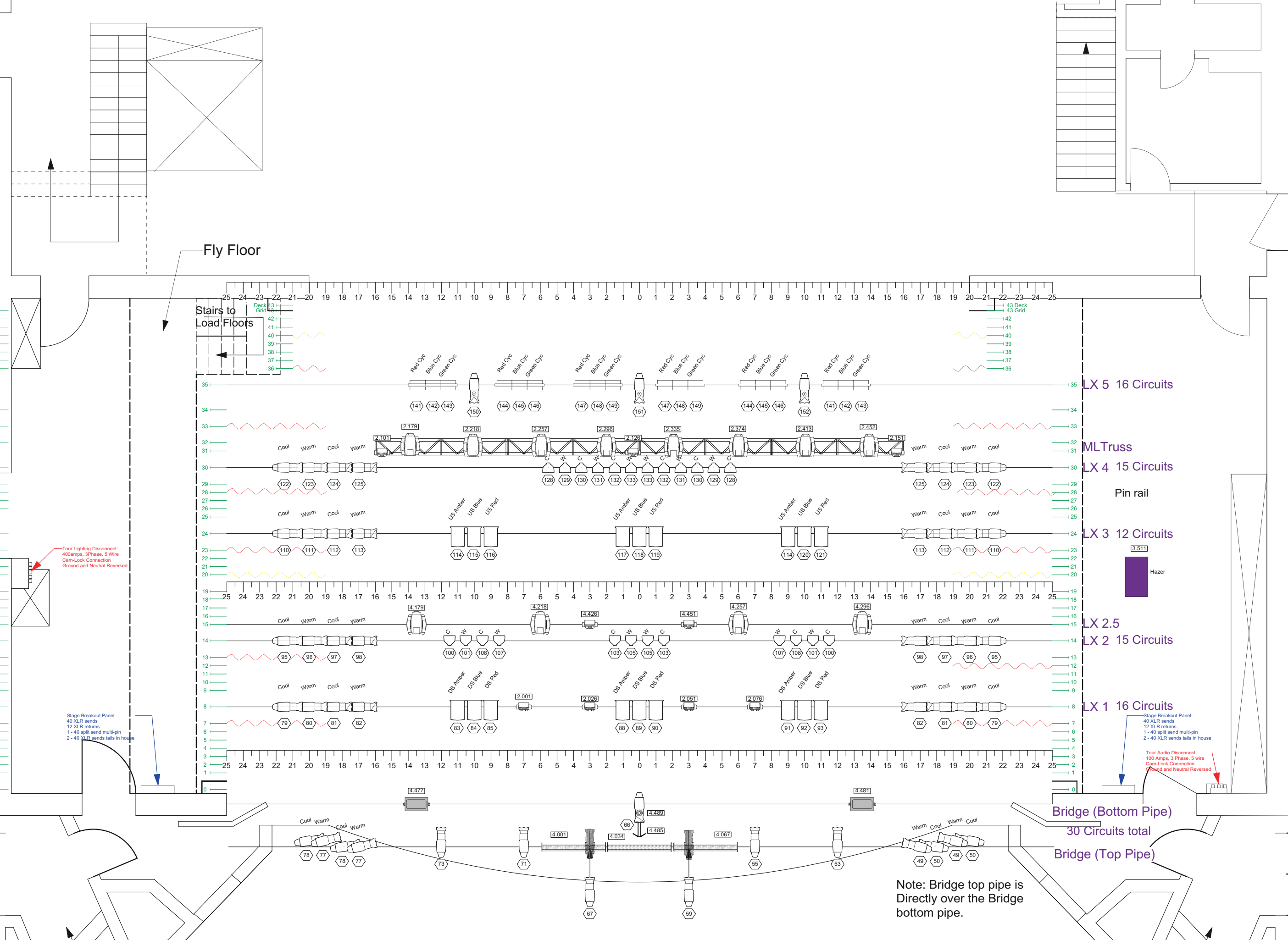

Tour Lighting Disconnect:
400amps, 3Phase, 5 Wire
Cam-Lock Connection
Ground and Neutral Reversed

Stage Breakout Panel
40 XLR sends
12 XLR returns
1 - 40 split send multi-pin
2 - 40 XLR sends tails in house

Stage Breakout Panel
40 XLR sends
12 XLR returns
1 - 40 split send multi-pin
2 - 40 XLR sends tails in house

Tour Audio Disconnect:
100 Amps, 3 Phase, 5 wire
Cam-Lock Connection
Ground and Neutral Reversed

Note: Bridge top pipe is
Directly over the Bridge
bottom pipe.

Bridge (Bottom Pipe)
30 Circuits total
Bridge (Top Pipe)

LX 5 16 Circuits

ML Truss

LX 4 15 Circuits

Pin rail

LX 3 12 Circuits

LX 2.5

LX 2 15 Circuits

LX 1 16 Circuits

Instruments in House Plot	Used
Lycian M2	2
Source 4 19deg	18
Source 4 26deg	17
Source 4 36deg	20
Source 4 50deg	3
Source 4 Zoom 15°-30°	24
Source 4 Zoom 25°-50°	6
Rama 7" Fresnel	18
S4 PAR WFL	24
CCT Far Cyc 3 Cells	6
ColorForce 48	3
Atomic 3000 Strobe	2
MAC Aura (Hung)	9
Mistral TC Profile	14
Accessories	Used
DMX Iris	5
I-Cue	5
B - Size Template Holder	3

Additional Stock	Available
Source 4 Fixture	46
19deg lens tube	9
26deg lens tube	15
36deg lens tube	18
50deg lens tube	17
90deg lens tube	1
Source 4 Zoom 15°-30°	4
Source 4 Zoom 25°-50°	2
Rama 7" Fresnel	12
CCT Far Cyc 3 Cells	2
ColorForce 48	7
Mistral TC Profile	2
Accessories	Available
Iris Kits	13
B - Size Template Holder	27
A - Size Template Holder	2

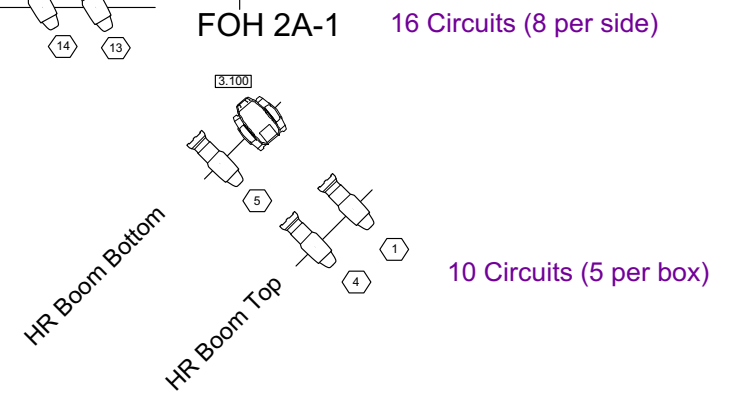
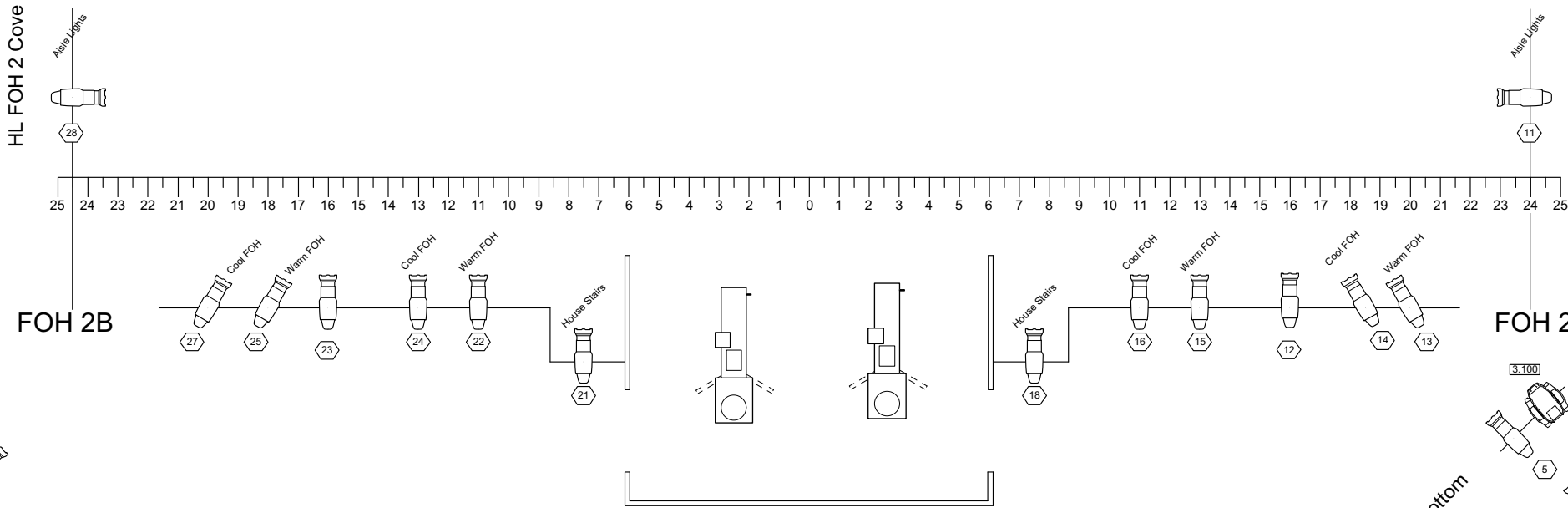
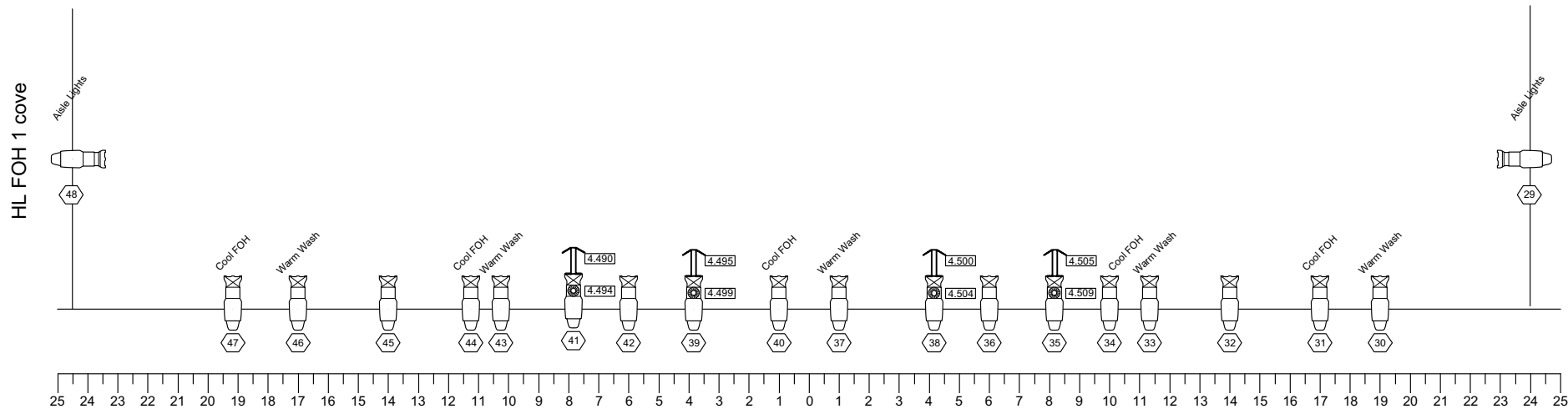
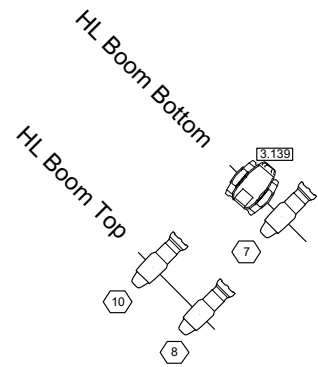

FOH 1 20 Circuits

FOH 2A-1 16 Circuits (8 per side)

10 Circuits (5 per box)